

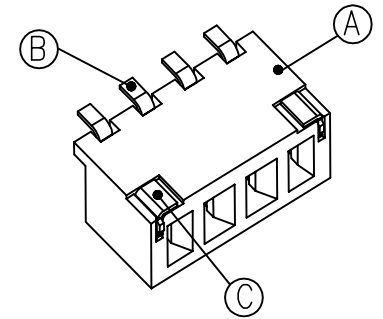

REV	ECN No.	DESCRIPTION	DESIGN	DATE
A0	-	Release	吴丹平	2017.10.26

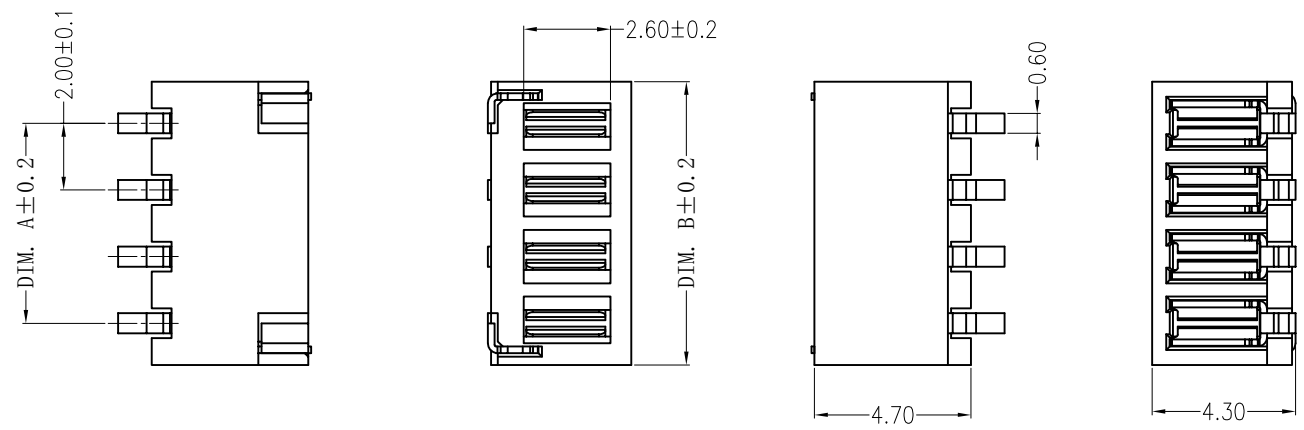

Circuit	Dimensions (mm)		
	DIM. A	DIM. B	DIM. C
03	4.00	6.50	4.50
04	6.00	8.50	6.50

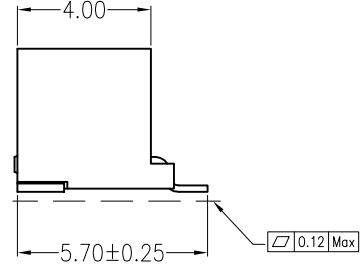
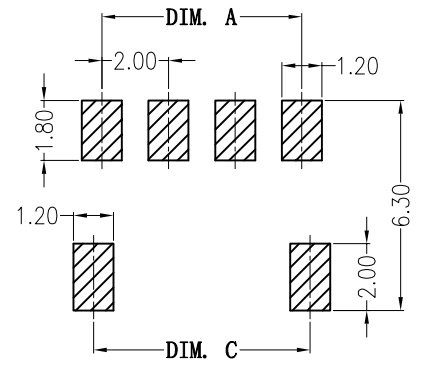

### 主要技术参数 Main Specifications

线 数 (Poles): 03 to 04  
 接触电阻 (Contact resistance):  $\leq 30m\Omega$   
 绝缘电阻 (Insulation resistance):  $\geq 1000M\Omega$   
 额定电压 (Rated voltage): 275V AC DC  
 额定电流 (Rated current): 1.0A AC DC  
 耐 电压 (Withstand Voltage): 1000V AC/minute  
 温度范围 (Temperature Range) : -40°C ~ +120°C

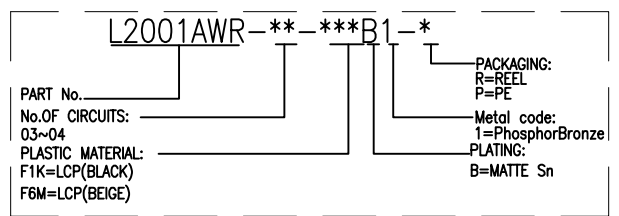

C	CONTACT		2 PCS	PhosphorBronze	MATTE Sn-Tip
B	COVER		2~4 PCS	PhosphorBronze	MATTE Sn-Tip
A	HOUSING		1 PCS	LCP	UL 94V-0, COLOR:BLACK/BEIGE
ITEM	COMPONENT	Q'TY	MATERIAL	FINISH	

**东莞市高迪电子有限公司**  
 DONG GUAN GAO DI ELECTRONICS CO., LTD

TITLE: 2.0Pitch 90°wafer smt type  
 PART NO.: L2001AWR-\*\*-\*\*\*B1-\*  
 DWG NO.: GCCP-0415  
 SCALE: 1 : 1  
 SHEET: 1 / 1

USE: CUSTOMER  
 APPD: 邵敬和  
 CHKD: 田峰  
 DR: 蒋建银

UNITS: mm